

R. H. WHITE.
COMPOUND ENGINE.

APPLICATION FILED DEC. 1, 1902.

NO MODEL.

2 SHEETS—SHEET 1.

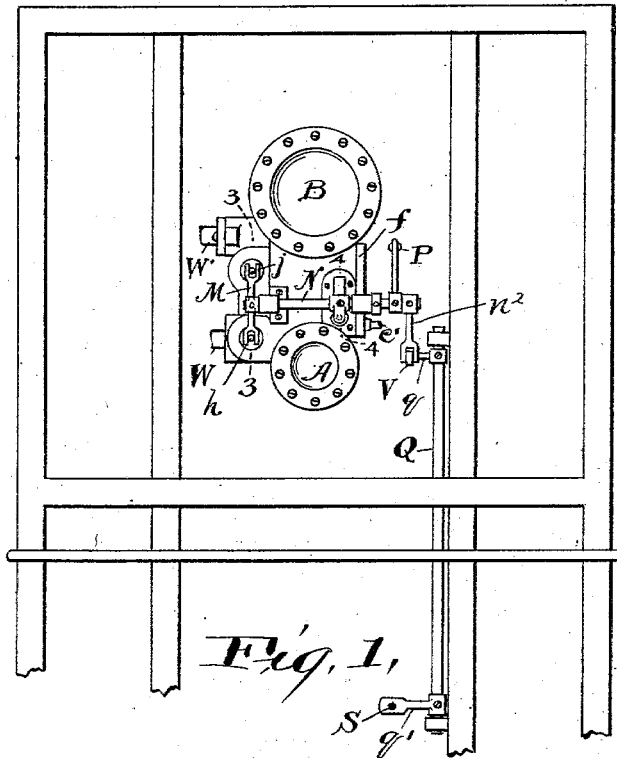

Fig. 1,

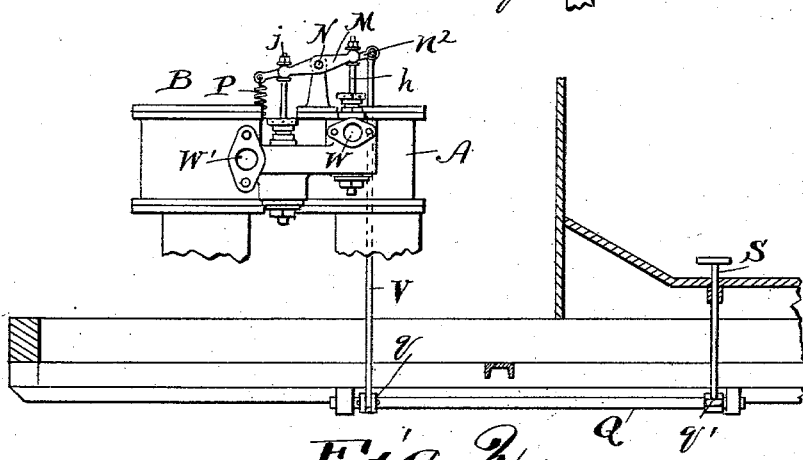

Fig. 2,

Witnesses
E. B. Gilchrist
H. M. Kiser

Inventor
Rollin H. White
 By his attorney
Thurston & Bates

R. H. WHITE.
COMPOUND ENGINE.
APPLICATION FILED DEC. 1, 1902.

NO MODEL.

2 SHEETS—SHEET 2.

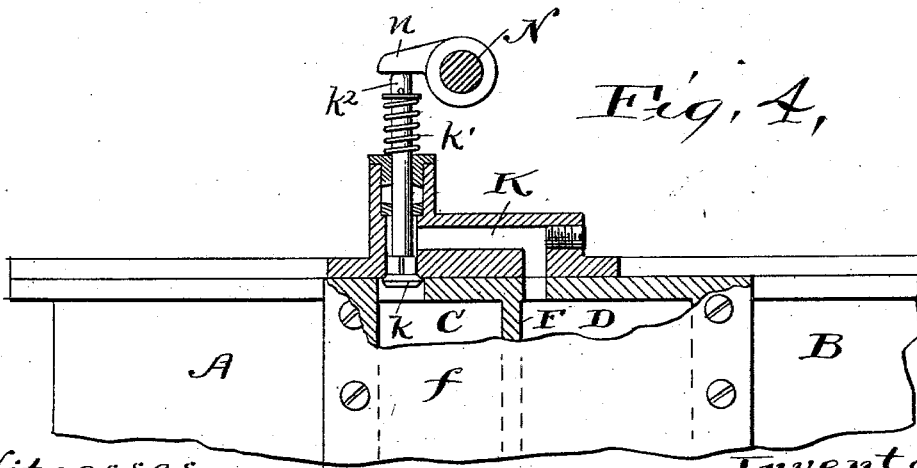
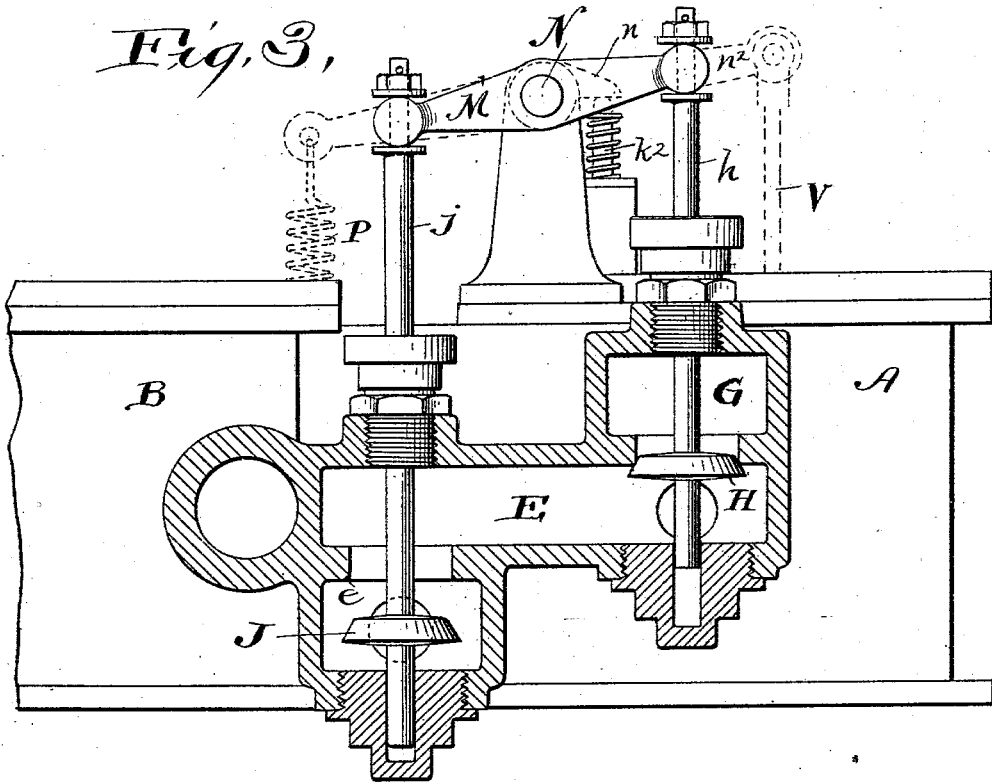

Witnesses
E. B. Gilchrist
H. M. Wiser

Inventor:
Rollin H. White
 By his attorneys
Shurston & Bates

UNITED STATES PATENT OFFICE.

ROLLIN H. WHITE, OF CLEVELAND, OHIO, ASSIGNOR TO THE WHITE SEWING MACHINE COMPANY, OF CLEVELAND, OHIO, A CORPORATION OF OHIO.

COMPOUND ENGINE.

SPECIFICATION forming part of Letters Patent No. 753,021, dated February 23, 1904.

Application filed December 1, 1902. Serial No. 133,330. (No model.)

To all whom it may concern:

Be it known that I, ROLLIN H. WHITE, a citizen of the United States, residing at Cleveland, in the county of Cuyahoga and State of Ohio, have invented a certain new and useful Improvement in Compound Engines for Automobiles, of which the following is a full, clear, and exact description, reference being had to the accompanying drawings.

The invention relates to means for transforming a two-cylinder compound engine into two simple cylinder-engines, and particularly the means whereby this result may be produced easily by the driver of an automobile, for which said engines furnish the motive power.

The invention consists in the construction and combination of parts hereinafter described, and pointed out definitely in the claims.

In the drawings, Figure 1 is a plan view of the engines and a part of the framework of the automobile which they are to drive. Fig. 2 is a side elevation of the engine and a sectional side view of so much of the automobile-framework as is necessary to show the relation of the parts. Fig. 3 is a sectional side view in the plane indicated by line 3 3 of Fig. 1. Fig. 4 is a view of the upper part of the opposite side of the engine, said view being partly in section in the plane indicated by line 4 4 of Fig. 1.

Referring to the parts by letters, A represents the high-pressure cylinder, and B the low-pressure cylinder, which, as usual, are parts of the same casting. In the part of the casting between these two cylinders is the high-pressure steam-chest C and the low-pressure steam-chest D, which are separated by a vertical partition F, both steam-chests being closed by the same plate *f*. Steam from the generator is delivered into the high-pressure steam-chest C through any suitable pipe, as *c'*. This steam is admitted from the steam-chest into the high-pressure cylinder through the valve-controlled ports in the usual way and is exhausted into a passage-way E, through which it passes into the low-pressure steam-chest D. From here it goes through valve-controlled

ports into the low-pressure cylinder, from which it is finally exhausted through a pipe W'. It has not been thought necessary to show the valves by which the admission of steam to the cylinders and its exhaustion from said cylinders is controlled, because such valves and their operating mechanisms may be of any suitable or well-known construction.

In order that the engines may be used as simple engines, a valve-controlled port G is provided, through which steam from the high-pressure cylinder may be discharged when the valve H is opened, and another valve-controlled port K is provided for establishing communication between the two steam-chests, the valve of which is closed when the engines are being compounded. A third valve J must also be provided, so that when the engines are being used as simple engines steam cannot flow from the low-pressure steam-chest into the passage-way E, connecting it with the high-pressure cylinder. My invention relates to the construction and arrangement of said ports and the valves and their operating mechanism, whereby, among other advantages, the steam-pressure will always be exerted to hold closed those valves which are closed at any time and whereby the position of the valves may be easily changed to compound the engine or not, as desired.

In the casting of which the two cylinders are a part is a passage-way E, connecting the high-pressure cylinder A with the low-pressure steam-chest. This passage-way E is deflected downward, and extending part way across this passage-way is a horizontal valve-seat *e*. The valve J is provided for engagement with this seat, and the valve in opening moves toward the low-pressure steam-chest, wherefore the steam-pressure therein assists in keeping the valve closed. The valve H, which closes the opening between the passage-way E and exhaust-port G, moves toward the exhaust-port G in closing, and thus the pressure of steam delivered from this cylinder into passage-way E assists in keeping this valve closed. These valves H and J are provided, respectively, with the stems *h* and *j*, which extend upward through suitable stuff-

ing-boxes, and their upper ends are operatively connected with opposite ends of a lever M, which is centrally secured to a rock-shaft N, mounted in standards on the engine-casting.

5 A spring P normally holds the lever and the valves in the position shown in Fig. 3. When in this position, the steam must pass from the high-pressure cylinder A through passage-way E into the low-pressure steam-chest D, and at this time the steam-pressure assists in holding the valve H closed. When, however,

10 the rock-shaft N is moved in opposition to the spring, this lever moves the two valves in the reverse direction, closing the valve J and opening the valve H. The exhaust-steam from the high-pressure cylinder will now after it has entered the passage-way E pass up through the port into the port G, from which the steam exhausts through the pipe W.

20 As will be seen in Fig. 4, there is a port K extending from the high-pressure steam-chest C to the low-pressure steam-chest D, which port is normally closed by a valve *k*, which is held to its seat by the pressure of steam in the high-pressure steam-chest. A spring *k'* assists in moving the valve to its seat. The stem *k''* of this valve extends out through a suitable stuffing-box, and its upper end lies beneath and is in contact with a finger *n*, attached to the rock-shaft N. When the engines

30 are being compounded and the valves H and J are in the position shown in Fig. 3, this valve is closed, as shown in Fig. 4, and there is no direct communication between the two steam-chests. When, however, the rock-shaft N is rocked, so as to reverse the position of the valves H and J and permit the steam from the high-pressure cylinder to exhaust directly through the pipe W, this valve K is opened

40 and steam from the high-pressure steam-chest passes directly into the low-pressure steam-chest and from thence into the low-pressure cylinder, as the valve permits. Both engines are now acting as simple engines. The steam from the low-pressure cylinder always exhausts through the pipe W'.

As the construction described is employed in connection with an automobile, there is a rock-shaft Q, mounted in suitable bearings,

50 secured to the automobile-frame. This rock-shaft has one arm *q*, which is connected by a link V with an arm *n''*, attached to the rock-shaft N. Another arm *q'* on this rock-shaft Q is arranged so that it may be operated by a push-pin S, which comes up through the floor of the carriage in a suitable position to be operated by the foot of the driver. When, therefore, he wishes the engines to act as simple engines, he simply pushes this rod down

60 with his foot. When he desires the engines to be compounded, he releases this push-pin, and the spring P will return the parts to the position shown in the drawings.

Having described my invention, I claim—

65 1. The combination of a high-pressure cyl-

inder, and a low-pressure cylinder, and their respective steam-chests, with a passage-way connecting the exhaust side of the high-pressure cylinder with the low-pressure steam-chest, a valve in said passage-way opening toward the low-pressure steam-chest, an exhaust-port connected with said passage-way, a valve for closing said exhaust-port by moving toward said exhaust-port, a passage-way connecting the two steam-chests, and a valve therefor which closes by moving away from the high-pressure steam-chest, and mechanism for simultaneously operating said valves, substantially as specified.

2. The combination of a high-pressure cylinder, and a low-pressure cylinder, and their respective steam-chests, with a passage-way connecting the high-pressure cylinder with the low-pressure steam-chest, a valve J in said passage-way having its valve-stem extended upward, an exhaust-port connected with said passage-way, a valve H for closing said exhaust-port having an upwardly-extended valve-stem, a passage-way connecting two steam-chests, and a valve *k* therefor which closes by moving away from the high-pressure steam-chest, and having an upwardly-extended valve-stem, a rock-shaft, two oppositely-extended arms secured thereto into operative engagement with the stems of the valves H and J, a finger on said rock-shaft in engagement with the stem of the valve *k*, and mechanism for moving said rock-shaft, substantially as described.

3. The combination of a high-pressure cylinder, and a low-pressure cylinder, and their respective steam-chests, with a passage-way connecting the high-pressure cylinder and low-pressure steam-chest, a valve in said passage-way for closing the same, an exhaust-port connected with said passage-way, and a valve for closing said exhaust-port, a passage-way connecting the two steam-chests, a valve for closing the same, the frame of an automobile upon which the parts referred to are supported, a rock-shaft mounted on said automobile-frame, operative connections between said rock-shaft and said valves whereby they are simultaneously operated, a push device extending through the floor of the automobile within reach of the operator's foot and in operative relation to said rock-shaft, substantially as specified.

4. The combination of a high-pressure cylinder, and a low-pressure cylinder, and their respective steam-chests, and an automobile-frame upon which said parts are secured, a passage-way connecting the high-pressure cylinder and low-pressure steam-chest, a valve in said passage-way for closing the same, an exhaust-port connected with said passage-way, a valve for closing said exhaust-port, a passage-way connecting the two steam-chests, a valve closing said passage-way, a rock-shaft having oppositely-extended arms, which are

operatively connected with the two valves first named, and having a finger which is operatively connected with the other valve, an operating-arm secured to said rock-shaft, a spring for moving this rock-shaft in one direction, a second rock-shaft mounted in the automobile-frame having two arms, a link connecting one of them with the operating-arm of the first-named rock-shaft, a push-rod engaging with the other arm, and extended to a position where it may be pressed downward by the foot of the driver of the automobile, substantially as specified.

5. The combination of a high-pressure cylinder, a low-pressure cylinder, which are parts of the same casting, there being in said casting a high-pressure steam-chest and a low-pressure steam-chest, an exhaust-port for the low-pressure cylinder, a passage-way connecting the exhaust side of the high-pressure cylinder with the low-pressure steam-chest, and

an exhaust-port communicating with said passage-way, with a valve for closing the communication between said passage-way and exhaust-port, a second valve for closing communication between said passage-way and the low-pressure steam-chest, a rock-shaft, a rocker connected therewith, and, on opposite sides of said rock-shaft, with stems of said two valves, a spring acting to close the first valve and to open the second valve, a passage-way connecting said two steam-chests, a valve for closing the same, a spring moving said valve in the closing direction, and an arm secured to said rock-shaft and engaging with the stem of said valve, substantially as described.

In testimony whereof I hereunto affix my signature in the presence of two witnesses.

ROLLIN H. WHITE.

Witnesses:

E. L. THURSTON,
E. B. GILCHRIST.