







R. H. WHITE.

DRIVING MECHANISM FOR AUTOMOBILES.

(Application filed Dec. 3, 1900.)

(No Model.)

4 Sheets—Sheet 4.

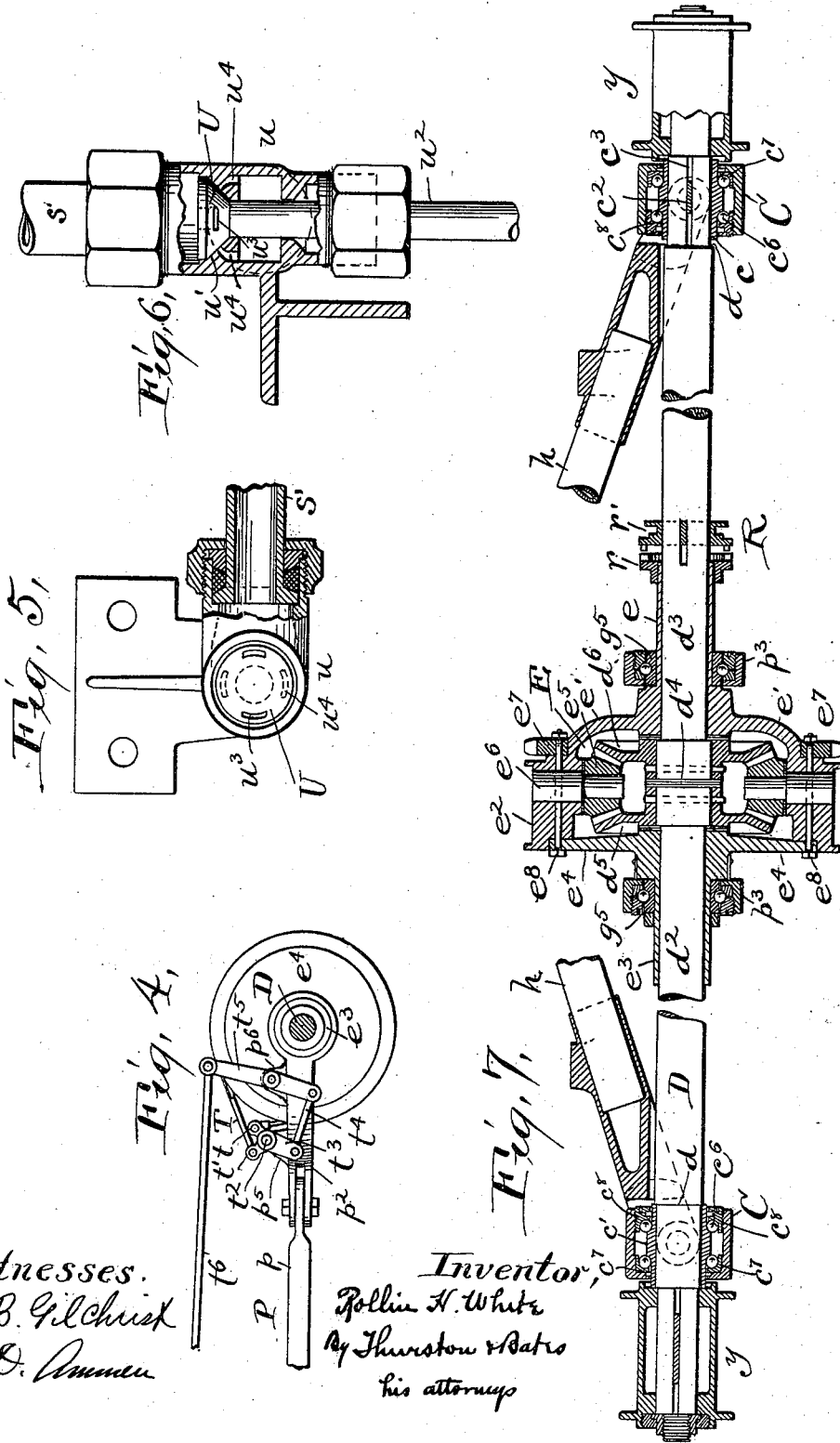

Witnesses.  
 E. B. Gilchrist  
 H. D. Ammen

Inventor,  
 Rollin H. White  
 By Thurston & Bates  
 his attorneys

# UNITED STATES PATENT OFFICE.

ROLLIN H. WHITE, OF CLEVELAND, OHIO, ASSIGNOR TO THE WHITE SEWING MACHINE COMPANY, OF CLEVELAND, OHIO, A CORPORATION OF OHIO.

## DRIVING MECHANISM FOR AUTOMOBILES.

SPECIFICATION forming part of Letters Patent No. 685,658, dated October 29, 1901.

Application filed December 3, 1900. Serial No. 38,407. (No model.)

*To all whom it may concern:*

Be it known that I, ROLLIN H. WHITE, a citizen of the United States, residing at Cleveland, in the county of Cuyahoga and State of Ohio, have invented a certain new and useful Improvement in Driving Mechanism for Automobiles, of which the following is a full, clear, and exact description, reference being had to the accompanying drawings.

The invention relates to the driving mechanism for automobiles. It does not relate to the motor, but to the mechanism whereby its motion is made effective to drive the vehicle under the varying conditions incident to the use of such machines.

In the drawings, Figure 1 is a side elevation of an automobile embodying my invention. Fig. 2 is a plan view of the same, the vehicle-body and some of the parts supported thereby being indicated by dotted lines only. Fig. 3 is a rear elevation. Fig. 4 is an enlarged side view of the brake-operating mechanism. Fig. 5 is a plan view of the throttle-valve. Fig. 6 is a side elevation, partly in section, of said valve. Fig. 7 is a rear view of the rear axle and a longitudinal sectional view of the parts which are immediately associated therewith.

Referring to the parts by letters, A represents the vehicle-body, and H represents the frame on which it is supported by the four springs F F' F'. The frame H consists of two side bars  $h'$   $h'$ , the front transverse bar  $h^2$ , and an arched transverse rear bar  $h$ . These bars are suitably fastened together and are preferably made of steel tubes. The front springs F' F' are clipped to the front bar  $h^2$  and the two rear springs are clipped to the rear bar  $h$ .

The rear or driving axle D is rotatably mounted in two sleeves C C, which are pivotally connected to the ends of the arched bar  $h$ , said pivots being transverse to the axle and substantially horizontal. The ends of the bar  $h$  are forked, and the forks  $h^3$  embrace said sleeves and receive the pivots  $c^5$ . These sleeves are the outer non-rotatable members of the ball-bearings for the axle, the rotatable members being cones  $c$   $c'$  on the axle. The fixed and adjustable cups  $c'$   $c^3$  in said sleeves form, with said cones, a race-

way in which antifriction-balls are confined. At least one of said cones, however, is slidable lengthwise on the axle between shoulder  $d$  thereon and the hub of the adjacent wheel  $y$ , which is secured to the axle. The bar  $h$  will straighten out more or less, especially when the vehicle is passing over a rough road, and the balls would be pinched and would bind in their bearings except for the possible longitudinal movement of one entire bearing on the axle. The movable cone  $c$  is connected to the axle by a longitudinal tongue  $c^2$  and groove  $c^3$ .

The rear axle is made in two parts  $d^2$   $d^3$ , arranged in axial line, with suitable washers  $d^4$ , if desired, between their adjacent ends. Loosely embracing one of these members is a sleeve  $e$ , having at one end a disk  $e'$ , with a cylindrical flange  $e^2$  at its periphery. A similar sleeve  $e^3$  loosely embraces the other axle member, and it has a disk or flange  $e^4$ , which is secured to the cylindrical flange referred to, thereby forming an inclosed gear-case E, surrounding the adjacent ends of the two axle members. Two beveled gears  $d^5$   $d^6$  are secured, respectively, to the ends of said axle members within said casing, their faces being toward one another. One or more beveled gears  $e^5$  are mounted on radial studs  $e^6$  in the gear-casing, and they mesh with both bevel-gears on the two axle members. These intermeshing bevel-gears attached to two aligned axle members and to a device rotatable upon said members is in itself old and its function is well known. The specific construction shown, however, is believed to be new and to be specifically an improvement over the prior constructions. The outer periphery of the cylindrical flange is utilized as a braking-surface, which is embraced by a band-brake. The long sleeves  $e$   $e^3$  of the two separable parts of said casing act to keep the two shaft members in alinement, and each carries a cone  $g^5$ , forming part of a ball-bearing, which will be presently described. A sprocket-wheel  $e^7$ , which is, as shown, merely a rim with sprocket-teeth on its outer periphery, is bolted to one side of the gear-case by the same bolts  $e^8$  which fasten the two members of the gear-case together.

The shaft M of the engine is mounted in

downwardly-extended arms  $m$ , which are parts of a frame rigidly fastened to the vehicle-body. A swinging frame  $K$  is supported from these arms, its axis being concentric with the axis of the shaft  $M$ . A sprocket-wheel  $k$  and attached gear  $k'$  are fast on a shaft  $k^2$ , which is rotatably mounted in the lower end of said swinging frame. The gear  $k'$  meshes with a gear  $m'$  on the shaft  $M$ , and a sprocket-chain  $O$  transmits motion from the sprocket-wheel  $k$  to the sprocket-wheel  $e'$ . The desired distance between the axes of these two sprocket-wheels is maintained by brace  $P$ , which consists of a bar  $p$  and the yoke-pieces  $p'$   $p^2$ , secured, as shown, to the ends of said bar. The two ends of the yoke-piece  $p'$  take over the ends of cylindrical projections on the swinging frame, which are axial with respect to said sprocket-wheel  $k$  and may be the projecting ends of the shaft  $k^2$ . This yoke-piece is connected with the bar  $p$  by a screw  $p^7$ , whose ends are oppositely threaded. This screw may be turned by the nut  $p^8$ , fixed to its middle portion, whereby the length of the brace  $P$  may be changed. The other yoke-piece  $p^2$  embraces the gear-case, and its arms  $p^3$  form the outer members of ball-bearings for the sleeves  $e$   $e^3$ , the cones  $g^5$  being the inner members thereof. The forward end of the yoke  $p^2$  is attached by a vertical pivot to the rear end of the bar  $p$ , which form of connection permits the floating of the carriage-body on its springs without causing the binding of the bearings of the opposite ends of the brace  $P$ .

The described mechanism permits the two axle members to rotate at different rates, which is a distinct advantage when the wheel is running on a curve. There are, however, conditions which arise in use wherein it is desirable that said two axle members shall be obliged to rotate in unison. A clutch  $R$  is therefore provided for connecting one of the sleeves  $e$  or  $e^3$  to the axle member which it embraces. A common jaw-clutch is shown, one part  $r$  being fixed to the sleeve  $e$  and the other part  $r'$  movable lengthwise only upon the shaft. The locking of one sleeve to its axle member prevents any independent rotation of the two axle members. The ends of the band-brake  $T$ , which embrace the periphery  $e^2$  of said gear-case, are pivotally connected with the ends of the two arms  $t$   $t'$ , secured to a rock-shaft  $t^2$ , which is mounted on the rear yoke  $p^2$ . An operating-arm  $t^3$  is also secured to this rock-shaft, and its outer end is connected by a link  $t^4$  with an operating-lever  $t^5$ , which is also pivoted on this same yoke. The upper end of this lever is pivotally connected with a draft-rod  $t^6$ , which extends forward, where it may be connected by suitable mechanism, whereby it may be moved backward and forward to set or release said brake.

The motor  $Z$ , as shown, is a steam-engine, which is supplied with steam from a boiler  $S$  through the pipe  $s'$  and past a throttle-valve

$U$ . This throttle-valve is shown in Figs. 5 and 6. It is a hollow casting  $u$ , having an internal tapered valve-seat  $u'$ , upon which the tapered valve  $U$  rests. The valve has a downwardly-extended stem  $u^2$ , by which it may be turned. Two elongated holes  $u^3$  extend down through the top of the valve, their lower ends passing through the tapered wall thereof in a position wherein they will normally be covered by the valve-seat. In the valve-seat are two vertical notches  $u^4$ , extending from the bottom to near the top thereof, and when the valve is turned the holes  $u^3$  are brought into alignment with said notches  $u^4$  to a greater or less extent, whereby steam may pass from above the valve into the space below in the valve-casing below said valve. On the lower end of the valve-stem is a crank-arm  $u^5$ , connected by a link  $w$  with a crank-arm  $w'$  on the lower end of the throttle-lever shaft  $W$ , which projects up through the body of the vehicle and has at its upper end an operating-lever  $w^2$ . The position of the link  $L$  of the engine is changed by the operation of a rock-shaft  $J$ , the connection between said rock-shaft and the link being such as is well known. This rock-shaft is operated or prevented from operating by the following novel mechanism: A rock-shaft  $N$  is mounted in brackets  $a$ , fastened to the vehicle-body  $A$ . It has one arm  $n$  which is connected by the rod  $n'$  with an arm  $j$  on the rock-shaft  $J$ . An arm  $n^2$  is also attached to the rock-shaft  $N$ , and to the outer end of this arm a handle-bar  $n^3$  is pivoted. A segmental plate  $n^4$ , which is concentric to the rock-shaft  $N$ , is also made fast to the vehicle-body, and it has notches  $n^5$  in its edge, with which a toe  $n^6$  on the handle-bar  $n^3$  is adapted to engage. A spring  $n^7$ , fastened to the arm  $n^2$  and bearing against said handle-bar  $n^3$ , holds said toe  $n^6$  in the notches, but permits the bar to be swung so as to release said toe, whereupon the rock-shaft  $N$  may be moved, with the result of operating the rock-shaft  $J$ , and thereby changing the position of said link.

The throttle-valve and its operating mechanism hereinbefore described is the subject-matter of another application on file in the Patent Office.

Having described my invention, I claim—

1. The combination of a vehicle-frame which includes an arched transverse bar, and two sleeves pivotally connected with the ends of said arched bar, with an axle mounted in the sleeves, one of which sleeves is movable lengthwise upon the axle, substantially as and for the purpose specified.

2. The combination of an axle carrying two ball-bearing cones, one of which is slidable lengthwise only upon said axle, combined with a transverse frame member, and two sleeves which are pivotally connected with said frame member and embrace said cones, and anti-friction-balls confined between said cones and sleeves, substantially as and for the purpose specified.

3. The combination of an axle having two ball-bearing cones, one of which is slidable only thereon, with a transverse arched member of a vehicle-frame having sleeves pivoted to its ends and embracing said cones, and anti-friction-balls confined between said sleeves and cones, substantially as and for the purpose specified.

4. The combination of an axle having one ball-bearing cone fixed to it and one movable lengthwise only upon it, with a bar forming part of a vehicle-frame, two sleeves pivoted to the ends of said bar and embracing said cones respectively, and balls interposed between said cones and sleeves, substantially as and for the purpose specified.

5. The combination of two alined axle members and beveled gears secured respectively to their proximate ends, with a gear-case inclosing said gears and rotatably mounted on both of said axle members, said gear-case having an external cylindrical braking-surface, and a sprocket-wheel secured to said case, a beveled gear mounted in and supported by said case on a radial axis, a driving sprocket-wheel, a chain connecting said sprocket-wheels, a distance-bar having its forward end pivotally supported in axial alinement with said driving-sprocket and having at its rear end a yoke loosely embracing said axle-sections, a brake engaging with the cylindrical flange on the gear-casing, and operating mechanism for said brake supported upon said yoke, substantially as and for the purpose specified.

6. A gear-case consisting of two parts, one having a sleeve, a circumferential disk, and an overhanging cylindrical flange, and the other having a sleeve and a circumferential disk which is fastened to said flange, combined with two alined axle members upon which said two sleeves are respectively mounted, two beveled gears secured respectively to said axle members within said gear-case, a beveled gear mounted in and supported by said case on a radial axis, a distance-bar having at its rear end a fork whose arms loosely embrace said two sleeves, and a driving-shaft, means for transmitting motion from said shaft to said gear-case, supports for the front end of said distance-bar whereby said distance-bar maintains the operative relationship between said gear-case and said driving-shaft, substantially as and for the purpose specified.

7. A gear-case consisting of two parts, one having a sleeve, a circumferential disk, and an overhanging cylindrical flange, and the other having a sleeve and a circumferential disk which is fastened to said flange, combined with two alined axle members upon which said two sleeves are respectively mounted, two beveled gears secured respectively to said axle members within said gear-case, a beveled gear mounted in and supported by said gear-case on a radial axis, a distance-bar having at its rear end a fork whose arms loosely embrace said two sleeves, a driving-

shaft, means for transmitting motion from said shaft to said gear-case, supports for the front end of said distance-bar whereby said distance-bar maintains the operative relationship between said gear-case and said driving-shaft, a band-brake embracing the cylindrical surface on the gear-case, and brake-operating mechanism supported on said rear yoke, substantially as and for the purpose specified.

8. The combination of two alined axle members having beveled gears secured respectively in their proximate ends, a gear-casing embracing said gears and having two oppositely-extending sleeves which are revolvably mounted on said axle members respectively, a sprocket-wheel secured to said gear-case, and a beveled gear mounted on a radial axis in said gear-case and supported thereby, a driving-shaft and swinging frame suspended in axial alinement therewith, a shaft mounted in said frame, intermeshing gears secured respectively to said shafts, a sprocket-wheel secured to the shaft which is mounted in the swinging frame, a sprocket-chain, a distance-bar having at its front end a yoke whose ends are pivotally connected with said swinging frame in axial alinement with the shaft supported thereby, and having at its rear end a yoke whose ends loosely embrace the two sleeves of the gear-case, substantially as and for the purpose specified.

9. A gear-case consisting of two parts, one having a sleeve, a circumferential disk, and an overhanging cylindrical flange, and the other having a sleeve and a circumferential disk which is fastened to said flange, combined with two alined axle members upon which said two sleeves are respectively mounted, two beveled gears secured respectively to said axle members within said gear-case, a beveled gear mounted in and supported by said case on a radial axis, a distance-bar having at its rear end a fork whose arms loosely embrace said two sleeves, and a driving-shaft, means for transmitting motion from said shaft to said gear-case, supports for the front end of said distance-bar whereby said distance-bar maintains the operative relationship between said gear-case and said driving-shaft, a band-brake embracing a cylindrical surface on said gear-case, a rock-shaft mounted on the rear yoke of the distance-bar, two angle-arms secured to said rock-shaft to which the ends of the brake-band are connected, and an operating-arm also secured to said rock-shaft, substantially as and for the purpose specified.

10. A gear-case consisting of two parts, one having a sleeve, a circumferential disk, and an overhanging cylindrical flange, and the other having a sleeve and a circumferential disk which is fastened to said flange, combined with two alined axle members upon which said two sleeves are respectively mounted, two beveled gears secured respectively to said axle members within said gear-case, a beveled gear mounted in and supported by said case on a radial axis, a distance-bar hav-

ing at its rear end a fork whose arms loosely embrace said two sleeves, and a driving-shaft, means for transmitting motion from said shaft to said gear-case, supports for the front end of said distance-bar whereby said distance-bar maintains the operative relationship between said gear-case and said driving-shaft, a band-brake embracing a cylindrical surface on said gear-case, a rock-shaft mounted on the rear yoke of the distance-bar, two angle-arms secured to said rock-shaft to which the ends of the brake-band are connected, and an operating-arm also secured to said rock-shaft, a lever pivoted to said yoke, a link connecting it to said operating-arm, and means for operating said lever, substantially as and for the purpose specified.

11. The combination of two alined axle members having bevel-gears secured to their proximate ends, a gear-case embracing said bevel-gears and rotatably mounted upon both of said axle members and having a cylindrical braking-surface, a bevel-gear rotatably mounted in said gear-case, mechanism for rotating the gear-case, a brace-bar having a rear yoke which embraces said axle members loosely, a band-brake engaging with said gear-

case, and brake-operating mechanism supported on the yoke of said brace-bar, substantially as and for the purpose specified.

12. The combination of a driving-axle, a sprocket-wheel mounted axially with respect to said axle and operatively connected therewith, a driving-shaft, a swinging frame suspended axially with respect to said shaft, a shaft mounted in the lower end of said swinging frame, a gear and a sprocket-wheel secured to the last-mentioned shaft, a gear secured to the driving-shaft, and a distance-bar having at its front end a yoke which is pivotally connected with said swinging frame in axial alinement with the shaft which it supports, a rear yoke-piece whose arms loosely embrace and are supported by the axle, and an intermediate bar which is connected with the rear yoke by a vertical pivot and is adjustably connected with the forward yoke, substantially as and for the purpose specified.

In testimony whereof I hereunto affix my signature in the presence of two witnesses.

ROLLIN H. WHITE.

Witnesses:

E. L. THURSTON,  
E. B. GILCHRIST.