

No. 676,790.

Patented June 18, 1901.

R. H. WHITE.

SYSTEM OF REGULATING STEAM BOILERS.

(Application filed July 5, 1900.)

(No Model.)

2 Sheets—Sheet 1.

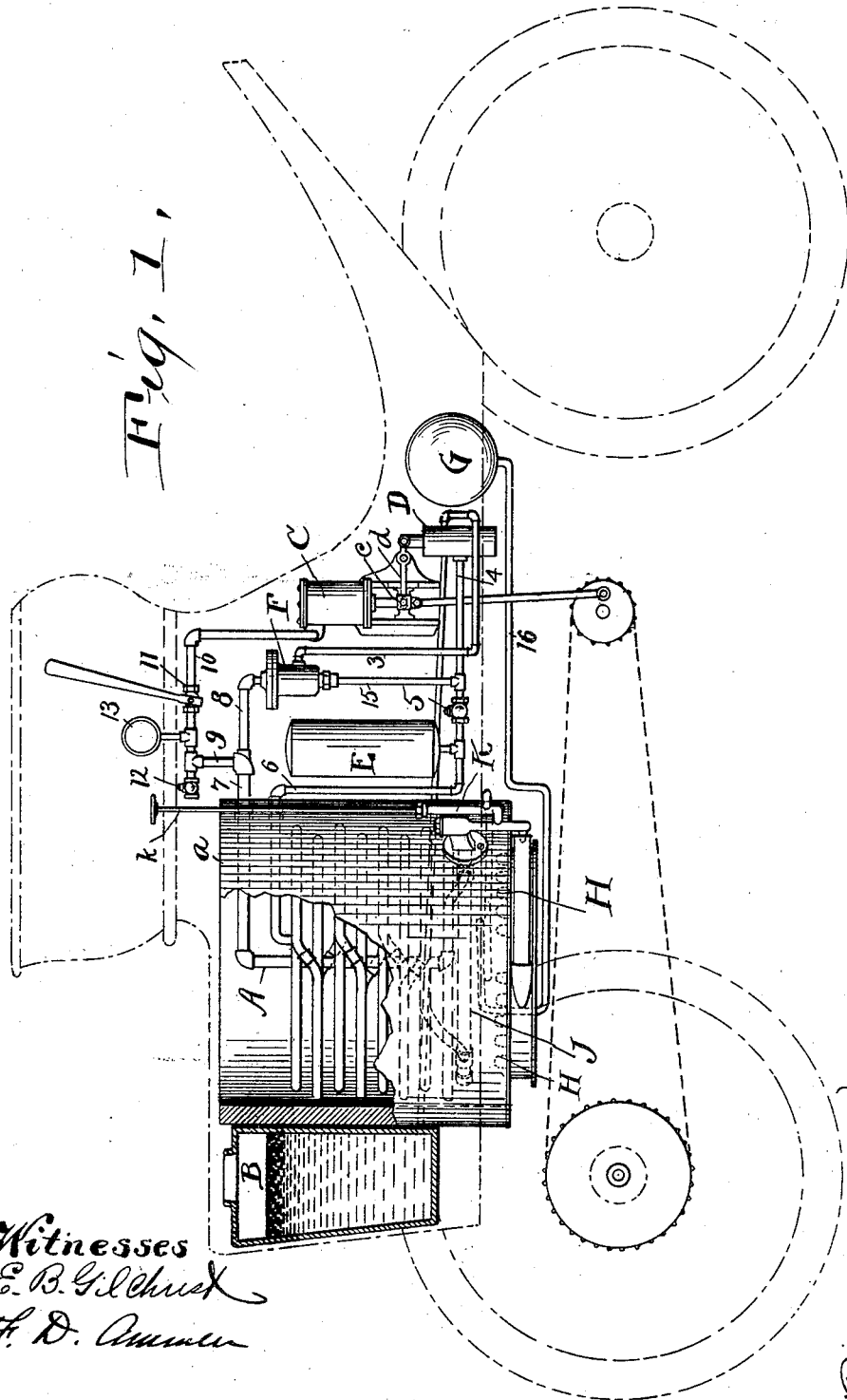

Fig. 1.

Witnesses
E. B. Gilchrist
F. D. Ammer

Inventor,
Rollin H. White,
 By *Thurston & Bates,*
Attys.

R. H. WHITE.
SYSTEM OF REGULATING STEAM BOILERS.

(Application filed July 5, 1900.)

(No Model.)

2 Sheets—Sheet 2.

Fig. 2,

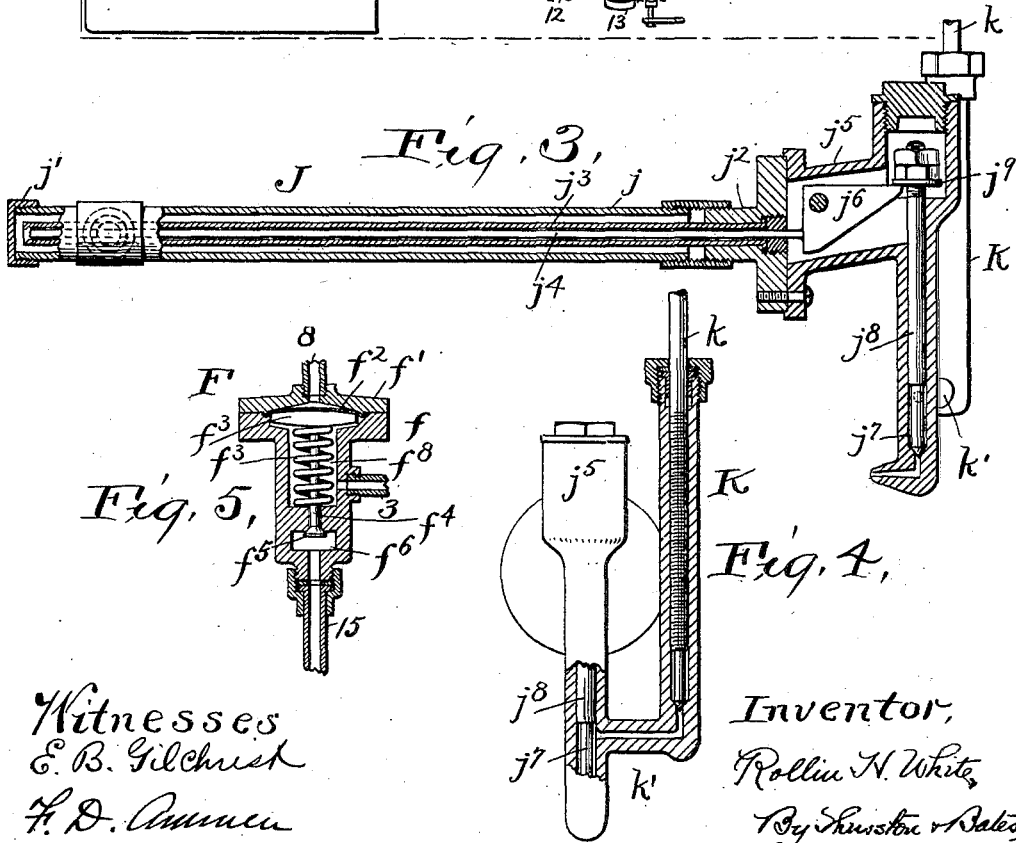
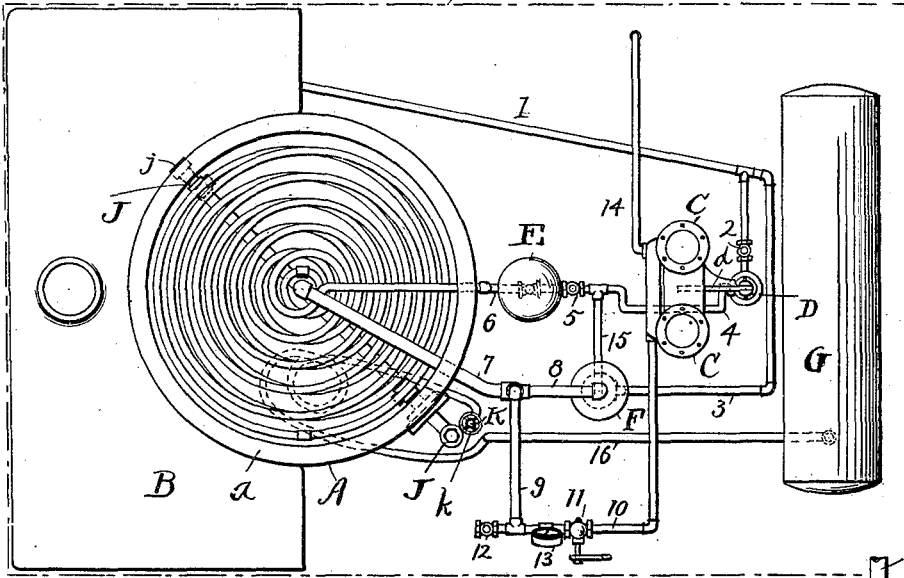

Witnesses
E. B. Gilchrist
H. D. Ammen

Inventor,
Rollin N. White,
By Skurston & Bates,
Attorneys.

UNITED STATES PATENT OFFICE.

ROLLIN H. WHITE, OF CLEVELAND, OHIO, ASSIGNOR TO THE WHITE SEWING MACHINE COMPANY, OF SAME PLACE.

SYSTEM OF REGULATING STEAM-BOILERS.

SPECIFICATION forming part of Letters Patent No. 676,790, dated June 18, 1901.

Application filed July 5, 1900. Serial No. 22,486. (No model.)

To all whom it may concern:

Be it known that I, ROLLIN H. WHITE, a citizen of the United States, residing at Cleveland, in the county of Cuyahoga and State of Ohio, have invented a certain new and useful Improvement in Systems of Regulating Steam-Boilers, of which the following is a full, clear, and exact description, reference being had to the accompanying drawings.

The invention relates solely to steam-generators of the "flasher" type, which have the capacity of superheating the steam which they generate and in which, therefore, the temperature and the pressure of the steam at the point where it is discharged from the generator bear no uniform relationship to each other. For example, the steam-pressure in such a generator may be anything from approximately zero up to the capacity of the generator, while at the same time its temperature at the delivery-point may be substantially the steam-table equivalent of the then-existing pressure or anything above it.

The object of this invention is to automatically control the generation and superheating of steam in a flasher, to the end that said generator may automatically generate and prepare for delivery to an engine superheated steam at substantially uniform pressure and artificial temperature and to accomplish this result regardless of the varying demands upon the generator for steam. It is not of course possible to prevent some variations in the pressure and temperature of the steam. In fact, the operation of the invention depends upon such variations. What the invention actually accomplishes is the speedy restoration of the desired pressure and temperature, and it attains this result by automatically correlating the quantities of water and fuel concurrently fed to the generator and burner, respectively, for immediate conjoint use in the production of the superheated steam.

Another object attained by the invention is the prevention of injury to the flasher by overheating it or by creating excessive steam-pressure therein.

The ultimate object is to provide a steam-generator for supplying an engine adapted to

be safely operated by persons relatively unskilled in the use of machinery, which will automatically and with the maximum of economy of water and fuel prepare for delivery to the engine an adequate supply of superheated steam in what may be called the "ideal" condition with respect to its temperature and pressure, meaning the condition in which the steam may be most economically and efficiently used. Such generators are of prime utility on steam-automobiles, which are commonly operated by relatively unskilled persons and whereon the supplies of water and of the combustible are limited. It is, however, useful in many other situations, which need not be here enumerated. This result—this automatic action—is attained by combining with a flasher two regulating devices respectively controlling the supply of the two substances, which by their consumption coact to produce superheated steam—viz., water and combustible—which regulating devices are caused to operate interdependently by the steam itself, (or, more specifically, by those two characteristics of the steam which the regulator devices by their coördinated and interdependent action maintain or restore,) whereby said water and combustible are automatically supplied in properly-correlated quantities to effect the desired result and are so supplied however much or in whatever particulars the condition of the steam with respect to its pressure or temperature, or both, may have been temporarily varied from the ideal condition. These two regulator devices do not necessarily operate simultaneously or relatively in the same direction at all times. They would utterly fail to accomplish the desired result if they did necessarily so operate, because under some conditions which arise in use the supply of one substance—water or combustible—must be increased and, concurrently, the supply of the other must be diminished. Under other circumstances the supply of both must be increased, and under still other circumstances the supply of both must be either diminished or shut off entirely. The two regulating devices which form a part of this invention do, however, act interdependently through the

generator and the steam therein to automatically increase or decrease the supply of water to the generator or the supply of combustible to the burner which heats the generator, or
 5 of both, as the then existing conditions require, whereby the water and heat are properly proportioned to bring about the desired result—viz., the maintenance, so far as possible, of the existing temperature and pressure of the steam in the generator or the
 10 speedy restoration of the steam therein to its ideal condition with respect to its temperature and the pressure.

The invention therefore consists, broadly,
 15 in the combination, with a steam-generator of the flasher type, of a regulator device for the water-supply controlled by the pressure of the steam in the generator and a regulator for the fuel-supply controlled by the temperature of the steam in the generator, which
 20 parts coact, as stated, to produce the result sought.

The invention also consists in the more specific combination of parts, as recited in
 25 the claims.

The drawings show my system of regulation applied specifically to an automobile.

Figure 1 is a sectional side elevation of my invention so embodied, the automobile body
 30 and wheels being shown in dotted lines; and Fig. 2 is a plan thereof. Fig. 3 is an enlarged vertical central section of the thermostatic regulator; and Fig. 4 is an end view thereof,
 35 partly in section. Fig. 5 is a vertical central section of the pressure-regulator for the water-supply.

The particular construction of thermostatic regulator for the fuel and pressure-regulator for the water is immaterial to the present
 40 broad invention. The forms in which I have herein illustrated these features are shown, described, and claimed in my prior applications, Serial No. 11,311, filed April 3, 1900,
 and Serial No. 223, filed January 3, 1900, respectively.
 45

Referring first to Figs. 1 and 2, A represents the boiler, formed of a continuous coil of pipe and inclosed in suitable casing *a*.
 50 The coils shown are plain spirals one above the other and connected together in series. Water is forced into the upper coil and progressively through the coils toward the lower coil, from which the steam is delivered, and the water is vaporized or flashed into steam
 55 at some points in the coils when the heat of the water and the pressure of the steam already formed are properly correlated. Steam-generators of this type belong to the class which are known as "flash-boilers,"
 60 which class includes those where the water is flashed into steam immediately it enters the boiler, as well as those, like the one shown, where the water is flashed into steam after it has traveled some distance in the boiler-tubes
 65 toward the steam-delivery end. "Flash-boilers" as the term is used herein is a generic

inclusive of steam-boilers having the mode of action described and having no drum or its equivalent for containing boiling water at a substantially constant water-level. The invention relates to boilers of this class, but not to any particular construction of such boilers.
 70

B represents the water-tank, which may be conveniently formed to partially embrace the boiler, as shown.
 75

C represents the steam-engine for driving the vehicle, and D a pump pumping the water from the tank to the boiler. This pump is shown as consisting simply of a cylinder with a plunger which is reciprocated by a
 80 pivoted lever *d*, actuated directly by the cross-head *c* of the engine, the check-valves of the pump being shown in the piping, as hereinafter explained.

E represents an air-chamber; F, the water-regulator; G, the tank for containing hydrocarbon fuel; H, the burner; K, the valve, and J the thermostatic regulator for the fuel.
 85

The piping connecting the various parts referred to is as follows: The pipe designated
 90 1 leads from the water-tank through the check-valve 2 to the pump and also by a branch 3 to the regulator F. The pipe 4 leads from the pump through the check-valve 5 to the pipe 6, which leads into the entrance
 95 end of the boiler. The steam end of the boiler leads out through the pipe 7, which divides and passes by the pipe 8 to the regulator F and by the pipes 9 and 10 through the throttle-valve 11 to the engine. A safety-valve 12 and a steam-gage 13 are shown leading from this pipe 11. The pipe 14 conveys
 100 exhaust-steam from the engine. A pipe 15 leads from the regulator F to the pipe 4 and is adapted to be connected by the regulator
 105 (when the steam-pressure is excessive) with the pipe 3, thus establishing a by-pass around the pump. A pipe 16 leads from the tank G over the burner H (for vaporization) to the hydrocarbon-valve K, which adjoins the ther-
 110 mostatic regulator J. This valve K is shown as a suitable casing mechanically governed by the screw-threaded needle-rod *k*.

In normal operation when the machine is running water is pumped through the pipe 1,
 115 the pump-cylinder, the pipe 4, the valves 2 and 5, (which valves each open toward the boiler and may be considered as constituting part of the pump,) and through the pipe 6 to the boiler, where it passes continuously through
 120 the coils of the boiler to the pipe 7, being converted into superheated steam during this passage by the hydrocarbon from the tank G, burned at the burner H. From the pipe 7 the steam passes to the engine C, being gov-
 125 erned by the throttle-valve 11. This is the operation when the hydrocarbon fed to the burner is no more than sufficient to superheat the steam to the required amount and all the steam being generated is used in the
 130 engine. When more steam is generated than used in the engine, the pressure in the boiler

increases, and when it reaches the maximum the regulator F operates to open the by-pass and prevent the admission of further water until the pressure decreases. This operation is accomplished as follows: The pressure-regulator F is shown in Fig. 5. It consists of a casing f , having a cap f^1 , between which is a diaphragm f^2 . The steam-pressure through the pipe 8 acting on this diaphragm tends to force downward the head f^3 on its under side, carried on the stem f^4 , on the other end of which stem is a conical valve f^5 , seating in a recess f^6 in the casing. This valve is normally held against its seat by a spring f^7 , surrounding the stem f^4 within the recess f^6 of the casing and bearing at one end against the base of that recess and the other against the head f^3 . The pipe 15 connects the recess f^6 with the pipe 4, leading from the pump to the check-valve 5, while the pipe 3 leads into the recess f^6 . Normally the spring f^7 maintains the valve f^5 on its seat, keeping pipes 3 and 15 disconnected. When, however, the steam-pressure reaches a predetermined maximum, it acts downward on the diaphragm f^2 , forcing the valve away from its seat and connecting together the two recesses f^6 to f^8 , and thus connecting the pipes 15 and 3. When this operation takes place, the pump operates idly, moving water in the pipes 4, 15, and 3 without pumping water to the boiler, the check-valve 5 preventing the water in the boiler from flowing backward. Thus whenever the pressure in the boiler reaches a predetermined maximum (sufficient to overcome the pressure of the spring f^7 and the water-pressure on the head of the valve f^5) the water is shut off and continues shut off until the boiler-pressure decreases to less than the spring-pressure.

The thermostatic regulator J operates to cut off the fuel-supply when the heat of the steam reaches a predetermined maximum. This regulator, as shown, includes a tubular casing j , which forms the connection between the lowest and the next to the lowest coils in the boiler, so that the steam is always flowing through this casing. At one end the casing is closed by a cap j^1 and at the other end by the head j^2 . Within the casing and secured to this head is the tube j^3 , closed at its outer end and preferably of copper, while within this tube j^3 is the rod j^4 , of iron or steel. Secured to the head j^2 is a casing j^5 , in which is pivoted the bell-crank j^6 , against which the rod j^4 may abut. The casing j^5 leads by a tubular opening j^7 to the burner H, while into this opening is a passage k^1 from the casing K, containing the main needle-valve k .

Within the tubular opening j^7 is a rod j^8 , having a reduced lower end extending below the passage k^1 and adapted to close or vary the opening to the burner, thus constituting a valve for the hydrocarbon. On the upper end of this rod j^8 are adjustable nuts j^9 , which form a shoulder bearing on the upper edge

of the bell-crank j^6 , wherefore the bell-crank supports this rod j^8 .

When the thermostat is not regulating the fuel, the rod j^8 is above the opening k^1 and the hydrocarbon flows to the burner. Now the tube j^3 being made of material of relatively high expansibility, as copper, and the rod j^4 of relatively less expansibility, as steel, when the two are heated by the steam the end of the tube j^3 will draw back from the bell-crank lever j^6 more than the rod j^4 will expand in length, wherefore the rod j^4 will be moved backward from the bell-crank lever and the latter will allow the rod j^8 to descend, partially or wholly closing the opening to the burner. This is what takes place when the temperature of the steam reaches a predetermined amount, the hydrocarbon being gradually turned off as the steam approaches a maximum. It will thus be seen that as soon as less steam is used less is generated, while whatever steam is generated is maintained at the proper degree of superheat, thus securing a very economical operation, as well as accomplishing the other objects heretofore set out.

Having described my invention, I claim—

1. The combination of a steam-generator of the flasher type with a regulator for the fuel-supply governed by the temperature of the steam in said generator and a regulator for the water-supply governed by the pressure of steam in said generator, substantially as and for the purpose specified.

2. The combination of a steam-generator of the flasher type, a burner for heating the same, means for supplying fuel to the burner, means for supplying water to the generator, a thermostatic regulator for governing the fuel-supply which regulator is inclosed in the generator, and a regulator for governing the water-supply which regulator is connected with the generator and operated by the steam-pressure therein, substantially as and for the purpose specified.

3. The combination of a steam-generator of the flasher type, a water-tank, means for forcing the water from the tank to the steam-generator, a hydrocarbon-burner for heating the steam-generator, a tank for containing hydrocarbon connected with the burner, a thermostatic regulator and a pressure-regulator connected with the steam-generator, the thermostatic regulator governing the supply of hydrocarbon from its tank to the burner and the pressure-regulator governing the supply of water from its tank to the boiler, substantially as described.

4. A steam-generator of the flasher type, a supply-tank adapted to contain water therefor, a pump adapted to force water from the tank to the steam-generator, a normally closed by-pass leading around the pump, which when opened allows the pump to operate without feeding the steam-generator, a pressure-regulator for controlling said by-

pass and connected with the steam-generator
and operated by the steam-pressure therein,
a burner for a fluid fuel for said steam-gen-
erator, and a thermostatic regulator connect-
5 ed with the steam-generator and operating to
govern the flow of fuel to said burner, sub-
stantially as described.

In testimony whereof I hereunto affix my
signature in the presence of two witnesses.

ROLLIN H. WHITE.

Witnesses:

E. L. THURSTON,
E. B. GILCHRIST.